

(1 : 2)

poids:
Gewicht:~600g
weight:

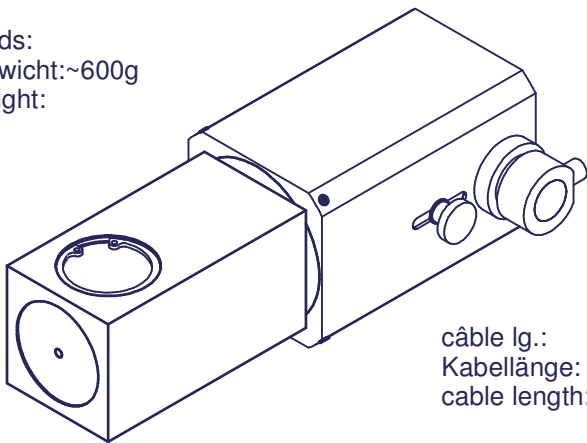

câble lg.:
Kabellänge:
cable length:

6V/20W

Mod. 1		Mod. 3		Origine		Echelle	Nom M.Saam
Mod. 2		Mod. 4		Rempl.		1:1	Date 27.01.2005
Spécification				Eclairage diascope halogène Durchlichtbeleuchtung halogen Transmitted illuminator halogene		Type	
				MA 212-10		\$20-0	
marcel aubert sa				bienne suisse		N° de document	
						ECL-...	
						N° de page	
						1 / 1	

S:\Bureau-Technique\Eclairage\MA 212-10\30000