

12V  
100W

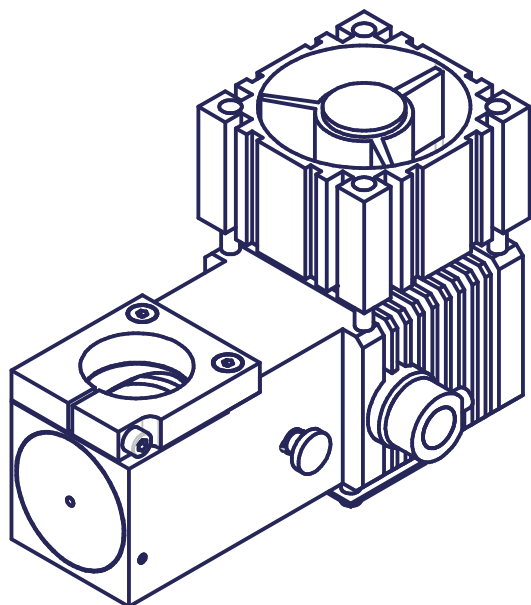

poids  
Gewicht : 0.8kg  
weight

F:\Eclairage\MA 213-13V-100W\$20.idw

Mod. 1		Mod. 3		Origine		Echelle	Nom	M.Saam
Mod. 2		Mod. 4		Rempl.		1:2	Date	27.01.2005
Libellé	ECLAIRAGE EPISCOPIQUE - halogène AUFLICHTBELEUCHTUNG - halogen INCIDENT LIGHT ILLUMINATOR - halogene			N° de plan	MA 213-13V-100W			
				Code article	ECL-...		N° de page	1 / 1

marcel - aubert - sa



Code article

ECL-...

N° de page

1 / 1