

6V/20W
 ou
 oder 12V/20W
 or

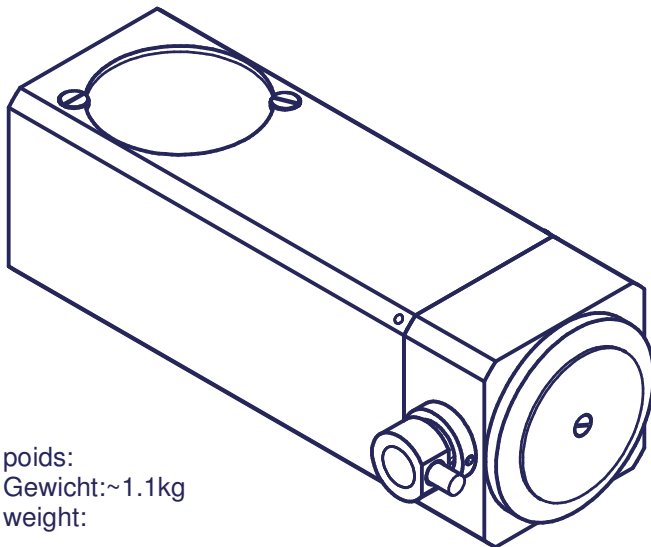

poids:
 Gewicht:~1.1kg
 weight:

Mod. 1	1088/05.07.2006	Mod. 3		Origine		Echelle	Nom DK	
Mod. 2		Mod. 4		Rempl.		1:2	Date 27.01.2005	
Spécification Eclairage diascopique halogène Durchlichtbeleuchtung halogen Transmitted illuminator halogene					Type MA 212-18			\$20-1
marcel aubert sa					bienne suisse	N° de document ECL-...		N° de page 1 / 1