

- 1. Course : 150mm
- 2. Course : 100mm
- 3. Blocage
- 4. Système de mesure linéaire

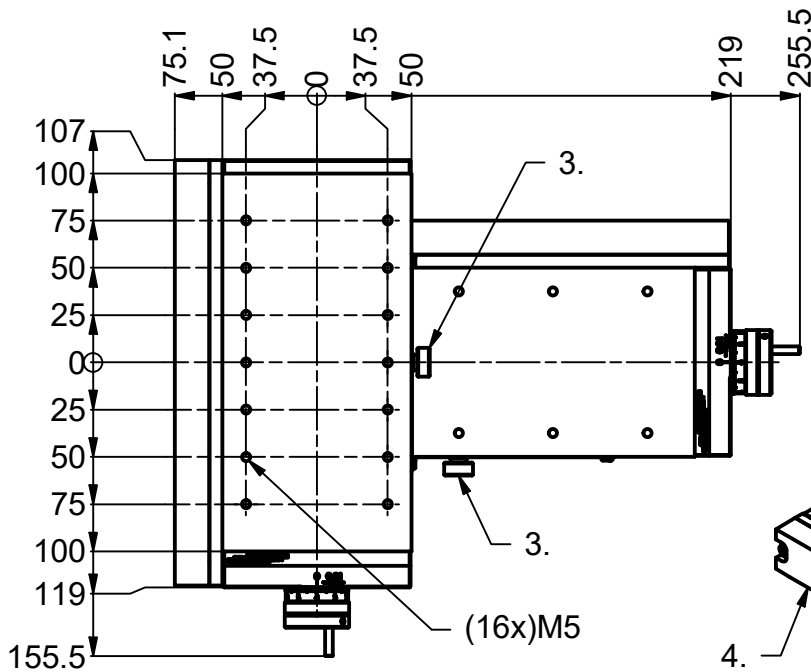

- 1. Hub: 150mm
- 2. Hub: 100mm
- 3. Blockierung
- 4. Lineares Messsystem

- 1. Stroke: 150mm
- 2. Stroke: 100mm
- 3. Blocking
- 4. Linear measuring system

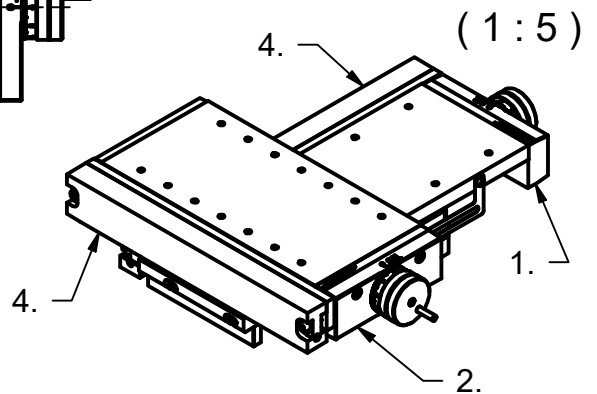

S:\Bureau-Technique\Dispositif\MA 159-008-44\$20.idw

Mod. 1		Mod. 3		Origine		Echelle	Nom	M.Saam
Mod. 2		Mod. 4		Rempl.		1:4	Date	27.02.2019
Libellé				N° de plan		Catégorie		
Table croisée 150x100 mm Kreuztisch 150x100 mm Cross table 150x100 mm				MA 159-008-44		\$20-0		
marcel - aubert - sa 						Code article	N° de page	
						DEP-024033	1 / 1	