

- 1. Course : 100mm
- 2. Course : 50mm
- 3. Blocage
- 4. Système de mesure linéaire

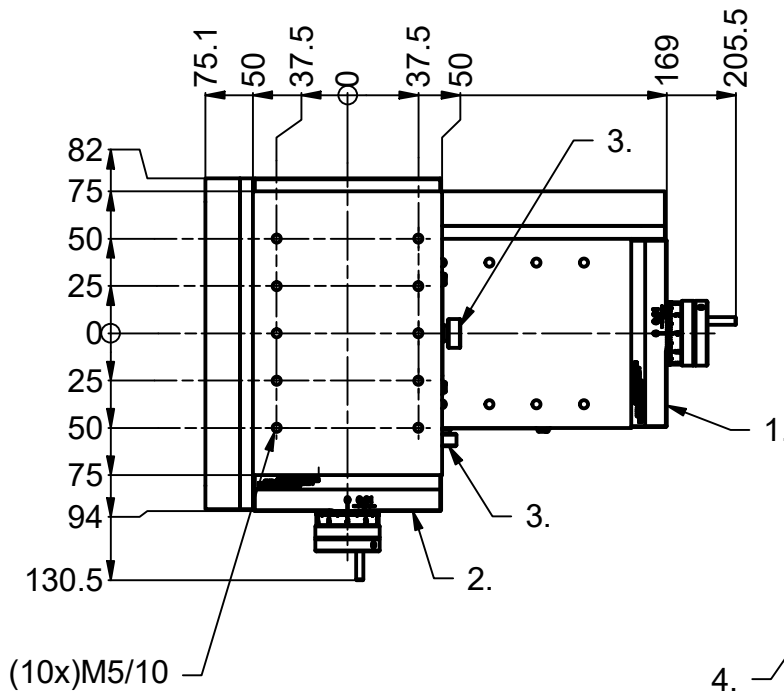

- 1. Hub: 100mm
- 2. Hub: 50mm
- 3. Blockierung
- 4. Lineares Messsystem

- 1. Stroke: 100mm
- 2. Stroke: 50mm
- 3. Blocking
- 4. Linear measuring system

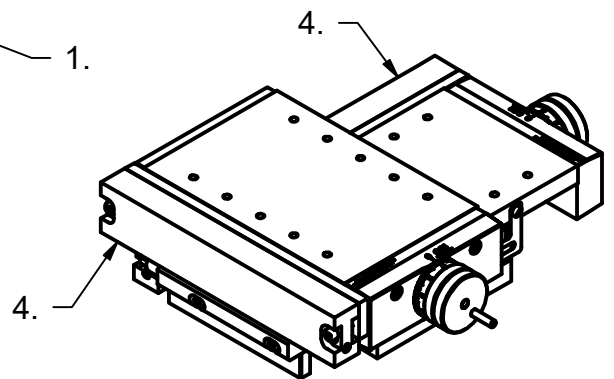

S:\Bureau-Technique\Dispositif\MA 159-008-42\$20.idw

Mod. 1		Mod. 3		Origine		Echelle	Nom	M.Saam
Mod. 2		Mod. 4		Rempl.		1:4	Date	27.02.2019
Libellé				N° de plan		Catégorie		
Table croisée 100x50 mm Kreuztisch 100x50 mm Cross table 100x50 mm				MA 159-008-42		\$20-0		
marcel - aubert - sa				Code article		N° de page		
				DEP-019794		1 / 1		